

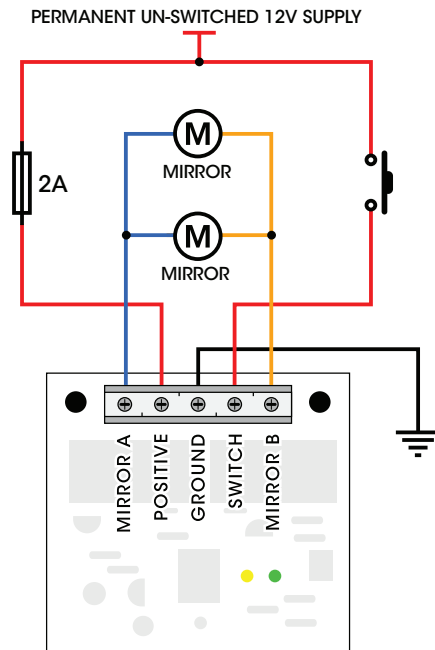

HONDA CRX FOLDING MIRROR UNIT



FOLD / OPEN SWITCH
OR ALARM TRIGGER

ENSURE BOTH SETS OF MIRROR
CONNECTIONS ARE SAME POLARITY

A 2 AMP INLINE FUSE IS
RECOMMENDED

ORIGINAL OEM MIRROR SWITCH
HAS 12V FEED TO IT, NO NEED
TO ADD ADDITIONAL SUPPLY

INSTALLATION

Take care to follow the above diagram.

There are two leds located on the PCB, a GREEN and YELLOW. Their purpose is to aid the initial installation. A direction change is indicated with the leds.

Ensure the wire pairs of the electric motors are correct (in the same direction) or the mirrors will operate opposite to each other (Match mirror connections to same connection on PCB).

The unit can be triggered from any momentary normally OPEN contact (actuating trigger voltage 9V - 15V). This can be manually via a switch or electronically such as a car alarm.

The unit will power the mirrors for 10 seconds, triggering the mirror switch again in this 10 second period will pause the mirrors for 3 seconds after which the mirrors will reverse.

Holding down the switch will not operate the mirrors, release the button to operate.

Ensure wires are stripped to the correct length and no bare wire is showing.

NOTE: Should you have purchased the optional PCB housing, a hole of appropriate size will need to be drilled for the cable entry. The PCB will be held securely in place with the compression of the padding. Screw the lid in place.

If installing a bare unit, secure the PCB to an appropriate location beneath the dash board with supplied cable ties.